

Thermal overload relays with phase-loss protective device

■ Description

FUJI TK series consists of a 3-heater element thermal overload relay and an phase-loss protective device. These two elements are assembled to make the relay unit. The overload relay characteristics are designed to meet the thermal characteristics of a squirrel-cage motors at the time of overload. A FUJI ADL mechanism is also provided to protect from phase-loss. This ADL mechanism is incorporated with the overload relay. The characteristics are coordinated with the temperature rise curve in stator winding at the time of motor phase-loss. They respond quickly to overloads. Other features include the following.

■ Characteristics

The operating characteristics of a thermal overload relays represents its tripping time and response current starting from cold or hot state.

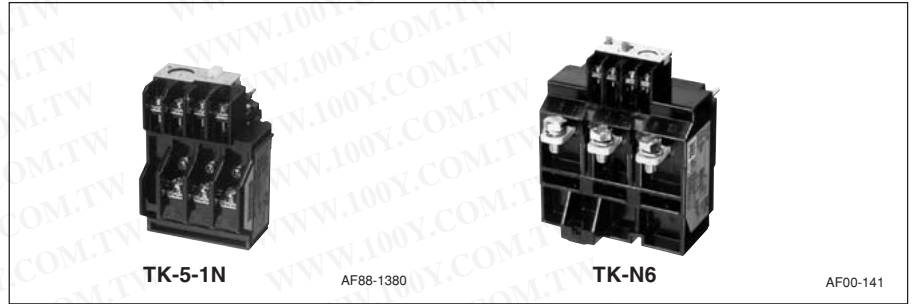

A trip-free mechanism, wide-range dial ampere adjustment, manual/auto reset chageover lever, operating indicator, and ambient temperature compensators. Types are available ranging from TK-0N to TK-N14.

■ Ordering information

Specify the following:
 1. Ordering code
 See pages 01/98.

Cold starting characteristics

In cold starting, tripping time is measured from the time when the temperature of the thermal overload relay is equal to the ambient temperature.

Hot starting characteristics

In hot starting, tripping time is measured from the time when the thermal overload relay reaches the steady state after non-tripping current flows two hours.

Standard	When all poles are equally energized				When all poles are not equally energized			Ambient temp.
	Operating limit Non-tripping	Tripping	Overload (hot start)	Locked rotor (cold start)	Phase-loss protection	Operating limit Non-tripping	Tripping Hot start	
IEC 60947-4-1	105% I _e	120% I _e (2h max.)	class 10A 150% I _e 2min max.	class 10A 720% I _e 2 to 10s max.	Not provided	3-phase: 105% I _e	2-phase: 132% I _e	20°C
			class 10 150% I _e 4min max.	class 10 720% I _e 4 to 10s max.			1-phase: 0 2h max.	
	class 20 150% I _e 8min max.	1-phase: 120% I _e 8min max.	class 20 720% I _e 6 to 20s max.	Provided	2-phase: 100% I _e	2-phase: 115% I _e		
			class 30 150% I _e 12min max.				class 30 720% I _e 9 to 30s max. *	1-phase: 90% I _e

**TK-0N, 5-1N
TK-0NH, 5-1NH**

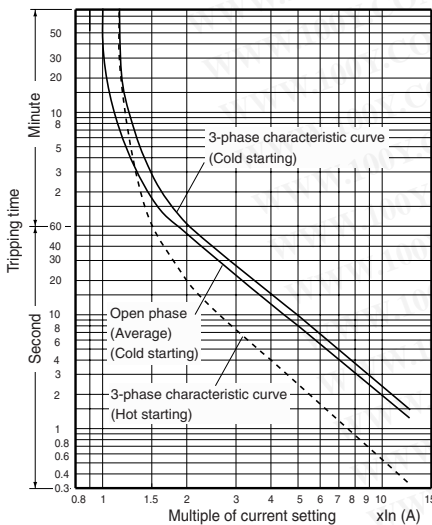

■ Dimensions, mm
 TK-0N to N14 types:
 Same as standard types
 See pages 01/103, 01/104.

**TK-N2, N3, N5, N6, N7, N8
TK-N2H, N3H, N6H**

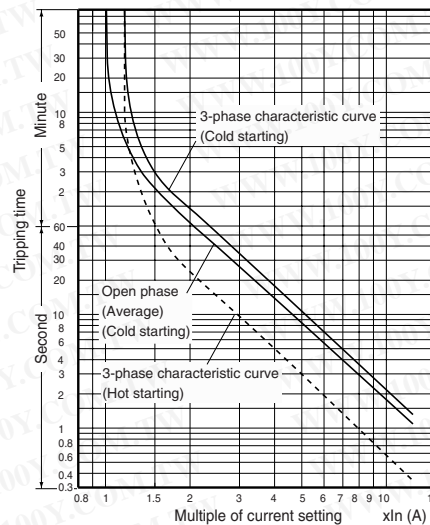

■ Wiring diagrams
 TK-0N to N14 types:
 Same as standard 3-heater element types
 See pages 01/107.

**TK-N10, N12, N14
TK-N10H, N12H, N14H**

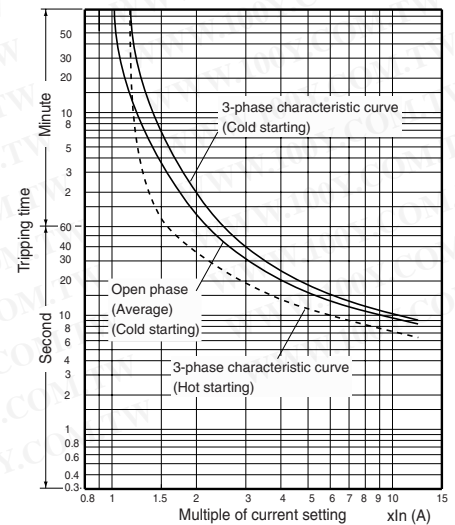

■ Ratings of auxiliary contact
 Same as standard types.
 See Page 01/102.

Standard type thermal overload relays

■ Description

- Highly reliable thermal overload relays
- FUJI thermal overload relays are designed to provide overload protection to meet the thermal characteristics of low voltage induction motors. Adjustable thermal overload relays give motors positive overcurrent protection. The starter contacts cannot be held closing under overload conditions. However, once the bimetal element has cooled, the reset button can be depressed and the motor can be restarted in the normal manner. Ordinarily this reset is carried out manually but the starter can be changed over to 'automatic reset' by means of a screw-driver.
- FUJI thermal overload relay is subjected to stringent testing in the factory to check performance and actual values are calibrated with the markings on the adjustable dial. Consequently, they provide a positive protection.
- Relays are also provided with ambient temperature compensators, so that their performance will be maintained in spite of temperature changes. The ambient temperature is regulated for 20°C.
- The heater elements are available for either 2- or 3-pole use.

Long time operating type

In the case of loads having large inertia moments such as blowers, winders or centrifuges the starting time is extended. This will cause the standard-type thermal overload relay to operate during starting so isolating the motor. If necessary FUJI will supply thermal relays with saturable reactors. (Time-delay type).

Quick operating type overload relays

The windings of submersible pump and compressor motors normally have a smaller overload capacity than those of standard motors, since they are generally cooled by the water and other medium being pumped. Q type overload relays will operate more quickly than the standard type in the face of a locked rotor current.



■ Features

- Isolated NO and NC contacts can be used with different potentials.
- Gold-flashed silver contact assures high contact reliability (TR-0N/3 to N14/3).
- Stable operating characteristics protect motors from burnout due to overload or locked rotor currents.
- Easy setting of current value with a calibrated dial.
- Both manual and auto reset available. A manual trip button is provided to facilitate sequence testing.
- Mechanical trip indication
- Trip-free mechanism is provided.
- Reset release button and trip indicator are optional accessories.

■ Warning

All FUJI thermal overload relays have been tested and calibrated at the factory. They should not be tampered with or stripped down at the job site since this would affect their accuracy. A special feature of the FUJI starter series is the ease by which the relay current ratings can be varied to match the requirements of the load. The changeover is effected by simply turning a dial to the new value required. The range of adjustment is approximately 100%–125%–150% and details are given overleaf.

■ Ordering information

Specify the following:

- Ordering code
 - Setting range code
- See page 01/98.

■ Type number nomenclature

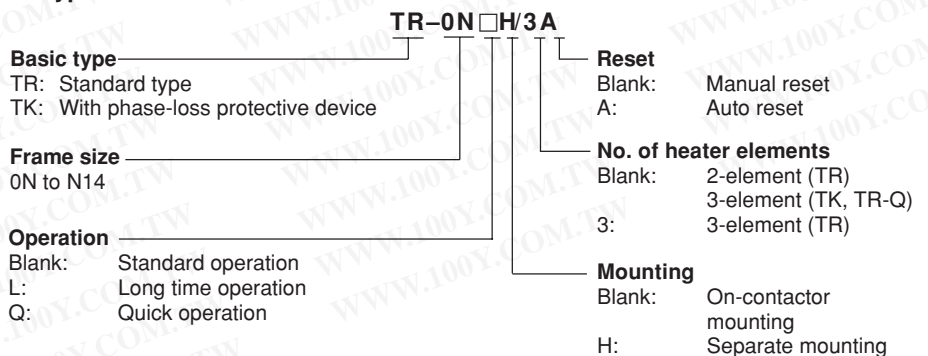

Thermal Overload Relays

TR series

■ Ordering code system

T R 2 0 B N W — T A
 ① ② ③④ ⑤ ⑥ ⑦ — ⑧ ⑨

① Product category

Description	Code
Thermal overload relay	T

② Series category

Description	Code
TR-N□ series	R

③④ Frame size

Frame size	Code	
	③	④
0N	1	3
5-1N	2	0
N2	3	5
N3	6	5
N5	9	3
N6	1	C
N7	1	F
N8	1	J
N10	2	C
N12	4	A
N14	6	A

⑤ Index

Type	Code
TR-0N, 5-1N	Blank
TR-N2 to N14	B

⑥ Version

Description	No. of element	Code
Standard	2	N
	3	D
Long time operation	2	L
	3	F
Quick operation	3	S
With phase-loss	3	E

⑦ Mounting

Description	Code
On-contactor mounting	W
Separate mounting	H

⑨ Reset

Description	Code
Manual reset	Blank
Auto reat	A

⑧ Thermal overload relay ampere setting range

Ampere setting range (A)	Code
0.1 — 0.15	A
0.13 — 0.2	B
0.15 — 0.24	C
0.2 — 0.3	D
0.24 — 0.36	E
0.3 — 0.45	F
0.36 — 0.54	G
0.48 — 0.72	H
0.64 — 0.96	J
0.8 — 1.2	K
0.95 — 1.45	L
1.4 — 2.2	M
1.7 — 2.6	N
2.2 — 3.4	P
2.8 — 4.2	R
4 — 6	S
5 — 8	T
6 — 9	U
7 — 11	V
9 — 13	W
12 — 18	X
16 — 22	Q
18 — 26	B
24 — 36	E
28 — 40	F
32 — 42	I
34 — 50	G
45 — 65	J
48 — 68	O
53 — 80	L
65 — 95	M
85 — 105	I
85 — 125	N
110 — 160	P
125 — 185	R
160 — 240	S
200 — 300	T
240 — 360	U
300 — 450	V
400 — 600	W

Ordering example

① Thermal overload relay T
 ② TR-□N series R
 ③④ Frame size: 5-1N 20
 ⑤ Index Blank
 ⑥ Standard type, 3-element D
 ⑦ On-contactor mounting W
 —
 ⑧ Ampere setting range 4-6A S
 ⑨ Auto reset A

① Thermal overload relay T
 ② TR-N□ series R
 ③④ Frame size: N3 65
 ⑤ Index B
 ⑥ With phase-loss protection E
 ⑦ On-contactor mounting W
 —
 ⑧ Ampere setting range 24-36A E
 ⑨ Manual reset Blank

TR20DW-SA

TR65BEW-E

■ Features

● Manual trip

These relays can be manually tripped for sequence inspection by pressing manual trip bar (TR-0N/3, TR-5-1N/3). A sequence inspection will be performed when the test button is pulled out. When the test button is pressed in, only the NC contact will turn OFF. The original status will be restored when the test button is then released.(TR-N2/3 to N8/3)

● Trip-free mechanism

Even if the reset button is carelessly pressed, this relay trips without trouble (Trip-free mechanism).

● Easy visual checking of operating status

Trip indicator and manual trip bar permit visual check of tripping status.



● Dial ampere setting

The setting dial uses a RC (Rated Current) marking which is set to the motor full load current.

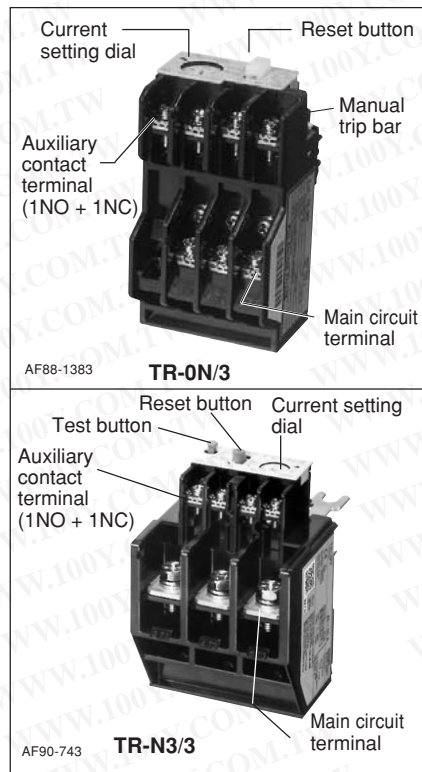

■ Versatile optional accessories
Trip indicator



AF00-291

Reset release



AF00-585

Base unit for separate mounting



AF00-159

■ Optional accessories

Description		Type	Ordering code	Used with thermal overload relay
Reset release	Lead length 300 mm	SZ-R1	TZ1R1	TR-0N/3, TR-5-1N/3, TK-0N, TK-5-1N
	500 mm	SZ-R2	TZ1R2	
	700 mm	SZ-R3	TZ1R3	TR-N10 to N14, TK-N10 to N14
You can reset these relays remotely on the front panels of switchboards.	Lead length 300 mm	SZ-R4	TZ2R4	TR-N2/3 to N8/3, TK-N2 to N8
	500 mm	SZ-R5	TZ2R5	
	700 mm	SZ-R6	TZ2R6	
Trip indicator	100–110V AC 50/60Hz	SZ-L100	TZ1L100	TR-0N/3, TR-5-1N/3, TK-0N, TK-5-1N
	200–220V AC 50/60Hz	SZ-L200	TZ1L200	TR-N10 to N14, TK-N10 to N14
Easier checking of trip status	100–110V AC 50/60Hz	SZ-L100N2	TZ2L100N2	TR-N2/3 to N8/3, TK-N2 to N8
	200–220V AC 50/60Hz	SZ-L200N2	TZ2L200N2	
Dial cover For protection against the current setting being changed in error		SZ-DA	SZ1DA	TR-0N/3, TR-5-1N/3, TK-0N, TK-5-1N TR-N2/3 to N14/3, TK-N2 to N14
Base unit for separate mounting The unit can be screw-mounted and rail-mounted.		SZ-HB	TZ1HB	TR-0N/3, TK-0N
		SZ-HC	TZ1HC	TR-5-1N/3, TK-5-1N
		SZ-HD	TZ2HD	TR-N2/3, TK-N2
		SZ-HE	TZ2HE	TR-N3/3, TK-N3
Terminal cover		SZ-T10	SZ1T10	Base unit for separate mounting SZ-HB
		SZ-T11	SZ1T11	Base unit for separate mounting SZ-HC
		SZ-T14	SZ2T14	For separate mounting TR-N2H/3, TK-N2H
		SZ-T15	SZ2T15	For separate mounting TR-N3H/3, TK-N3H
		SZ-RN6T	SZ2RN6T	For separate mounting TR-N6H/3, TK-N6H
		SZ-T12	TZ1T12	TR-0N/3, TK-0N
		SZ-T13	TZ1T13	TR-5-1N/3, TK-5-1N
		SZ-T16	SZ2T16	TR-N2/3, TK-N2
		SZ-T17	SZ2T17	TR-N3/3, TK-N2

Thermal Overload Relays

TR series

Standard type

■ Selection guide/Standard type

On-contactor mounting	3-element 2-element	TR-0N/3 (TR13DW) TR-0N (TR13NW)	TR-5-1N/3 (TR20DW) TR-5-1N (TR20NW)	TR-N2/3 (TR35BDW) TR-N2 (TR35BNW)	TR-N3/3 (TR65BDW) TR-N3 (TR65BNW)				
Separate mounting	3-element 2-element	TR-0NH/3 (TR13DH) TR-0NH (TR13NH)	TR-5-1NH/3 (TR20DH) TR-5-1NH (TR20NH)	TR-N2H/3 (TR35BDH) TR-N2H (TR35BNH)	TR-N3H/3 (TR65BDH) TR-N3H (TR65BNH)				
Contactor to be combined		SC-03	SC-0 SC-05	SC-4-0	SC-4-1 SC-5-1	SC-N1	SC-N2	SC-N2S	SC-N3
Ampere setting range (A)	Code	A	0.1 – 0.15	0.1 – 0.15	0.1 – 0.15				
		B	0.13 – 0.2	0.13 – 0.2	0.13 – 0.2				
		C	0.15 – 0.24	0.15 – 0.24	0.15 – 0.24				
		D	0.2 – 0.3	0.2 – 0.3	0.2 – 0.3				
		E	0.24 – 0.36	0.24 – 0.36	0.24 – 0.36				
		F	0.3 – 0.45	0.3 – 0.45	0.3 – 0.45				
		G	0.36 – 0.54	0.36 – 0.54	0.36 – 0.54				
		H	0.48 – 0.72	0.48 – 0.72	0.48 – 0.72				
		J	0.64 – 0.96	0.64 – 0.96	0.64 – 0.96				
		K	0.8 – 1.2	0.8 – 1.2	0.8 – 1.2				
		L	0.95 – 1.45	0.95 – 1.45	0.95 – 1.45				
		M	1.4 – 2.2	1.4 – 2.2	1.4 – 2.2				
		N	1.7 – 2.6	1.7 – 2.6	1.7 – 2.6				
		P	2.2 – 3.4	2.2 – 3.4	2.2 – 3.4				
		R	2.8 – 4.2	2.8 – 4.2	2.8 – 4.2				
		S	4 – 6	4 – 6	4 – 6	4 – 6	4 – 6		
		T	5 – 8	5 – 8	5 – 8	5 – 8	5 – 8		
		U	6 – 9	6 – 9	6 – 9	6 – 9	6 – 9		
		V	7 – 11	7 – 11	7 – 11	7 – 11	7 – 11	7 – 11	7 – 11
		W		9 – 13	9 – 13	9 – 13	9 – 13	9 – 13	9 – 13
		X			12 – 18	12 – 18	12 – 18	12 – 18	12 – 18
		Q				16 – 22			
		B					18 – 26	18 – 26	18 – 26
		E					24 – 36	24 – 36	24 – 36
		F						28 – 40	28 – 40
		I						32 – 42	
		G							34 – 50
		J							45 – 65
		O							48 – 68
		L							53 – 80*
		M							65 – 95*
		I							85 – 105*

On-contactor mounting	3-element 2-element	TR-N5/3 (TR80BDW) TR-N5 (TR80BNW)	TR-N6/3 (TR1CBDW) TR-N6 (TR1CBNW)	TR-N7/3 (TR1FBDW) TR-N7 (TR1FBNW)	TR-N8/3 (TR1JBDW) TR-N8 (TR1JBNW)	TR-N10/3 (TR2CBDW) TR-N10 (TR2CBNW)	TR-N12/3 (TR4ABDW) TR-N12 (TR4ABNW)	TR-N14/3 (TR8ABDW) TR-N14 (TR8ABNW)		
Separate mounting	3-element 2-element	–	TR-N6H/3 (TR1CBDH) TR-N6H (TR1CBNH)	–	–	TR-N10H/3 (TR2CBDH) TR-N10H (TR2CBNH)	TR-N12H/3 (TR4ABDH) TR-N12H (TR4ABNH)	TR-N14H/3 (TR8ABDH) TR-N14H (TR8ABNH)		
Contactor to be combined		SC-N4	SC-N5	SC-N6	SC-N7	SC-N8	SC-N10	SC-N11	SC-N12	SC-N14
Ampere setting range (A)	Code	B	18 – 26	18 – 26						
		E	24 – 36	24 – 36						
		F	28 – 40	28 – 40						
		G	34 – 50	34 – 50						
		J	45 – 65	45 – 65	45 – 65	45 – 65				
		L	53 – 80	53 – 80	53 – 80	53 – 80				
		M		65 – 95	65 – 95	65 – 95	65 – 95			
		I		85 – 105						
		N			85 – 125	85 – 125	85 – 125			
		P			110 – 160*	110 – 160	110 – 160	110 – 160	110 – 160	
		R				125 – 185	125 – 185	125 – 185	125 – 185	
		S					160 – 240	160 – 240	160 – 240	
		T						200 – 300	200 – 300	
		U							240 – 360	240 – 360
		V							300 – 450	300 – 450
		W								400 – 600

- Notes:
- TR-N10/3 to N14/3 types are provided with CTs.
 - Max. setting ranges of these starters are as shown in the table on the right.
 - When ordering the thermal overload relays for starter use, select the applicable setting range.
- () : Basic ordering code (When ordering phase-loss protective type, enter the version code E instead of D)
- * : Separate mounting only

Motor starter	Maximum applicable heater range (A)	
	200–240V	380–440V
SW-03/3H	7–11	6–9
SW-4-0/3H	12–18	12–18
SW-N1/3H	24–36	24–36
SW-N2S/3H	34–50	34–50
SW-N4/3H	53–80	53–80
SW-N6/3H	85–125	85–125

■ Selection guide/Long time operating type

On-contactor mounting	3-element	–	–	–	–	TR-N2L/3 (TR35BFW)	TR-N3L/3 (TR65BFW)		
	2-element	–	–	–	–	TR-N2L (TR35BLW)	TR-N3L (TR65BLW)		
Separate mounting	3-element	TR-0NLH/3 (TR13FH)	TR-5-1NLH/3 (TR20FH)	TR-2NLH/3 (TR35BFH)	TR-N3LH/3 (TR65BFH)				
	2-element	TR-0NLH (TR13LH)	TR-5-1NLH (TR20LH)	TR-N2LH (TR35BLH)	TR-N3LH (TR65BLH)				
Contactor to be combined		SC-03	SC-0 SC-05	SC-4-0	SC-4-1 SC-5-1	SC-N1	SC-N2	SC-N2S	SC-N3
Ampere setting range (A)	Code	L	0.95 – 1.45	0.95 – 1.45	0.95 – 1.45	0.95 – 1.45			
	M	1.4 – 2.2	1.4 – 2.2	1.4 – 2.2	1.4 – 2.2	1.4 – 2.2			
	N	1.7 – 2.6	1.7 – 2.6	1.7 – 2.6	1.7 – 2.6	1.7 – 2.6			
	P	2.2 – 3.4	2.2 – 3.4	2.2 – 3.4	2.2 – 3.4	2.2 – 3.4			
	R	2.8 – 4.2	2.8 – 4.2	2.8 – 4.2	2.8 – 4.2	2.8 – 4.2			
	S	4 – 6	4 – 6	4 – 6	4 – 6	4 – 6	4 – 6	4 – 6	
	T	5 – 8	5 – 8	5 – 8	5 – 8	5 – 8	5 – 8	5 – 8	
	U	6 – 9	6 – 9	6 – 9	6 – 9	6 – 9	6 – 9	6 – 9	
	V	7 – 11	7 – 11	7 – 11	7 – 11	7 – 11	7 – 11	7 – 11	7 – 11
	W		9 – 13	9 – 13	9 – 13	9 – 13	9 – 13	9 – 13	9 – 13
	X			12 – 18	12 – 18	12 – 18	12 – 18	12 – 18	12 – 18
	B					18 – 26	18 – 26	18 – 26	18 – 26
	E						24 – 36	24 – 36	24 – 36
F							28 – 40	28 – 40	
G							34 – 50	34 – 50	
J								45 – 65	
L								53 – 80*	
M								65 – 95*	

On-contactor mounting	3-element	TR-N5L/3 (TR80BFW)	TR-N6L/3 (TR1CBFW)	TR-N7L/3 (TR1FBFW)	TR-N10L/3 (TR2CBFW)	TR-N12L/3 (TR4ABFW)	TR-N14L/3 (TR8ABFW)			
	2-element	TR-N5L (TR80BLW)	TR-N6L (TR1CBLW)	TR-N7L (TR1FBLW)	TR-N10L (TR2CBLW)	TR-N12L (TR4ABLW)	TR-N14L (TR8ABLW)			
Separate mounting	3-element	–	TR-N6LH/3 (TR1CBFH)	–	TR-N10LH/3 (TR2CBFH)	TR-N12LH/3 (TR4ABFH)	TR-N14LH/3 (TR8ABFH)			
	2-element	–	TR-N6LH (TR1CBLH)	–	TR-N10LH (TR2CBLH)	TR-N12LH (TR4ABLH)	TR-N14LH (TR8ABLH)			
Contactor to be combined		SC-N4	SC-N5	SC-N6	SC-N7	SC-N8	SC-N10	SC-N11	SC-N12	SC-N14
Ampere setting range (A)	Code	B	18 – 26	18 – 26						
	E	24 – 36	24 – 36							
	F	28 – 40	28 – 40							
	G	34 – 50	34 – 50							
	J	45 – 65	45 – 65	45 – 65	45 – 65					
	L	53 – 80	53 – 80	53 – 80	53 – 80					
	M		65 – 95	65 – 95	65 – 95					
	N			85 – 125	85 – 125	85 – 125	85 – 125			
	P			110 – 160*	110 – 160	110 – 160	110 – 160	110 – 160	110 – 160	
	R					125 – 185	125 – 185	125 – 185	125 – 185	
	S						160 – 240	160 – 240	160 – 240	
	T							200 – 300	200 – 300	
	U								240 – 360	240 – 360
V								300 – 450	300 – 450	
W									400 – 600	

Notes: Maximum setting ranges of these starters are as shown in the table below.

Select the applicable setting range when ordering the thermal overload relays for starter use.

(): Basic ordering code

*: Separate mounting only

Motor starter	Maximum applicable heater range (A)	
	200–240V	380–440V
SW-03/2L, 3L	7–11	6–9
SW-N2S/2L, 3L	34–50	34–50
SW-N4/2L, 3L	53–80	53–80
SW-N6/2L, 3L	85–125	85–125

Thermal Overload Relays

TR series

Quick operating type

■ Selection guide/Quick operating type

On-contactor mounting	3-element	TR-0NQ (TR13SW)		TR-5-1NQ (TR20SW)		TR-N2Q (TR35BSW)	
Separate mounting	3-element	-		-		-	
Contactor to be combined		SC-03	SC-0 SC-05	SC-4-0	SC-4-1 SC-5-1	SC-N1	SC-N2
Rated operational current (A)	200-240V 380-440V	11 9	13 12	18 16	22 22	27 30	39 37
Ampere setting range (A)	Code	M	M	M	M		
		N	N	N	N		
		P	P	P	P		
		R	R	R	R		
		S	S	S	S		
		T	T	T	T		
		U	U	U	U		
		V	V	V	V		
		W	W	W	W		
		X		X	X	12 - 18	12 - 18
		B				18 - 26	18 - 26
		E					24 - 36

On-contactor mounting	3-element	TR-N3Q (TR65BSW)		TR-N5Q (TR80SW)	
Separate mounting	3-element	TR-N3Q (TR65BSW)		-	
Contactor to be combined		SC-N2S	SC-N3	SC-N4	SC-N5
Rated operational current (A)	200-240V 380-440V	52 48	65 65	80 80	105 105
Ampere setting range (A)	Code	B	B	B	B
		E	E	E	E
		F	F	F	F
		G	G	G	G
		J	J	J	J
		L	L	L	L
		M	M	M	M

Notes: *1 Thermal overload relay with phase-loss protection is available with *1 marked setting ranges of TR-0NQ, TR-5-1NQ and all setting ranges of TR-N2Q to N5Q.

Type numbers are TK-0NQ, TK-5-1NQ, TK-N2Q to N5Q. The setting ranges of these TK-□Q type relays are as same as those of the above setting ranges.

*2 Separate mounting only.

() Basic ordering code

■ Ratings of auxiliary contact

Type	Rated thermal current (A)	Rated voltage (V)	Rated AC operational current (A)	Rated DC operational current (A)
TR-0N, 5-1N TR-0N/3, 5-1N/3 TK-0N, 5-1N TR-0NQ, 5-1NQ	3	24 100-120 200-240 380-440 500-600	3 (0.3)* 2.5 (0.3)* 2 (0.3)* 1 (0.3)* 0.6 (0.3)*	1.1 (0.3)* 0.28 0.14 - -
TR-N2 to N8 TR-N2/3 to N8/3 TK-N2 to N8 TR-N2Q to N5Q	5	24 100-120 200-240 380-440 500-600	3 (0.5)* 2.5 (0.5)* 2 (0.5)* 1 (0.5)* 0.6 (0.5)*	1.1 (0.3)* 0.28 0.14 - -
TR-N10 to N14 TR-N10/3 to N14/3 TK-N10 to N14	5	24 100-120 200-240 380-440 500-600	3 (0.3)* 2.5 (0.3)* 2 (0.3)* 1 (0.3)* 0.6 (0.3)*	1.1 (0.3)* 0.28 0.14 - -

Notes: Conforming to Class AC-15, DC-13, IEC, JIS, and JEM.

() * NO contact of auto reset type.

Thermal Overload Relays

TR series

■ Dimensions, mm Long time operating type TR-N3L, N3L/3

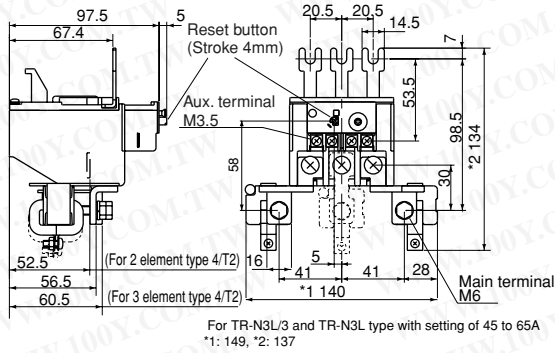

TR-N6L, N6L/3 On-contactor mounting

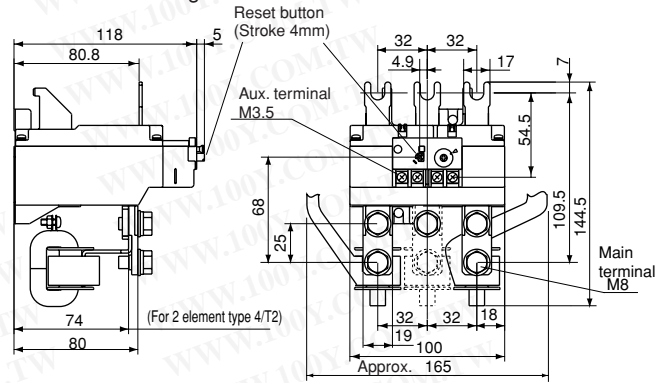

TR-N3LH, N3LH/3 On-contactor mounting

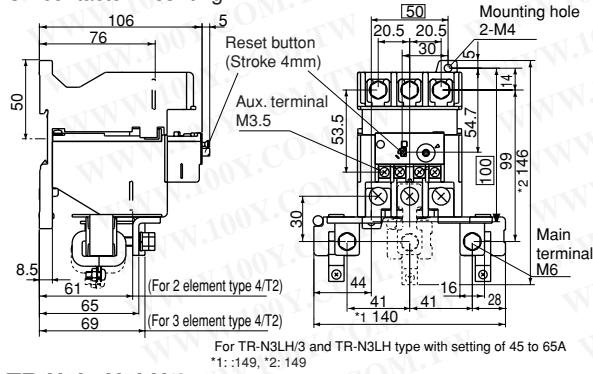

TR-N6LH, N6LH/3

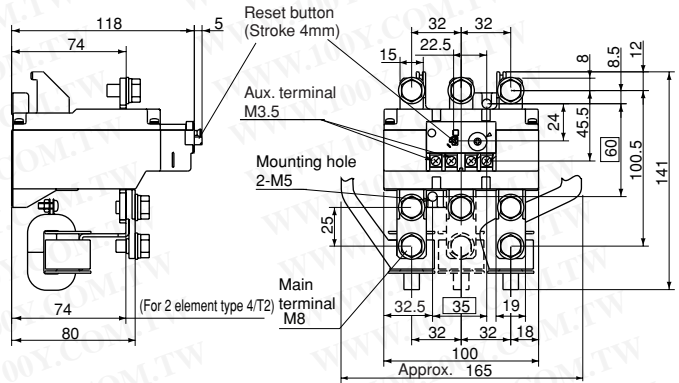

TR-N5L, N5LH/3 On-contactor mounting

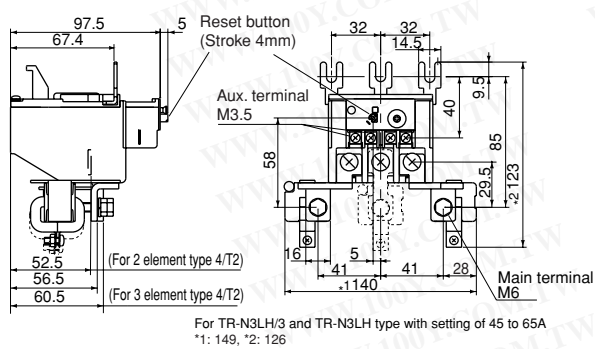

TR-N7L, N7L/3 On-contactor mounting

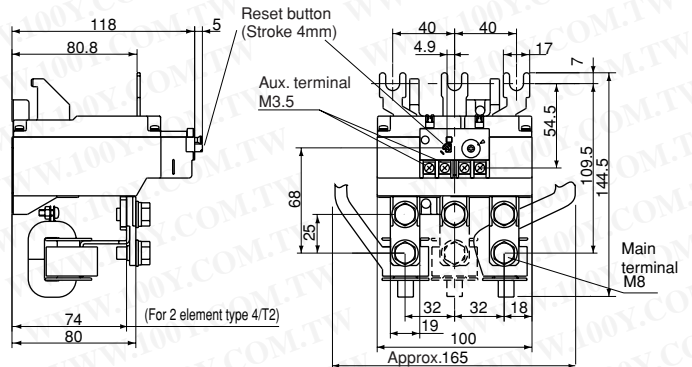

Note: TR-N10L, N10LH, N12NL, N12LH, N14L and N14LH types have the same dimensions as standard types. See pages 01/105.

■ Mass/Long time operating type

On-contactor mounting Type	Mass	Separate mounting Type	Mass	On-contactor mounting Type	Mass	Separate mounting Type	Mass
-		TR-0NLH	0.4kg	TR-N6L	1.54kg	TR-N6LH	1.6kg
-		TR-0NLH/3	0.5kg	TR-N6L/3	1.85kg	TR-N6LH/3	1.91kg
-		TR-5-1NLH	0.42kg	TR-N7L	1.54kg	-	
-		TR-5-1NLH/3	0.52kg	TR-N7L/3	1.85kg	-	
TR-N2L	0.56kg	TR-N2LH	0.65kg	TR-N10L	1.85kg	TR-N10LH	1.5kg
TR-N2L/3	0.68kg	TR-N2LH/3	0.77kg	TR-N10L/3	1.85kg	TR-N10LH/3	1.5kg
TR-N3L	0.63kg	TR-N3LH	0.74kg	TR-N12L	2.3kg	TR-N12LH	2.25kg
TR-N3L/3	0.77kg	TR-N3LH/3	0.88kg	TR-N12L/3	2.3kg	TR-N12LH/3	2.25kg
TR-N5L	0.63kg	-		TR-N14L	3.5kg	TR-N14LH	4kg
TR-N5L/3	0.77kg	-		TR-N14L/3	3.5kg	TR-N14LH/3	4kg

■ Dimensions, mm
Optional accessories
Trip indicator

SZ-L100
SZ-L200

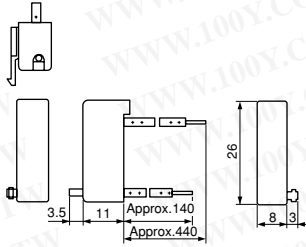

SZ-L100N2
SZ-L200N2

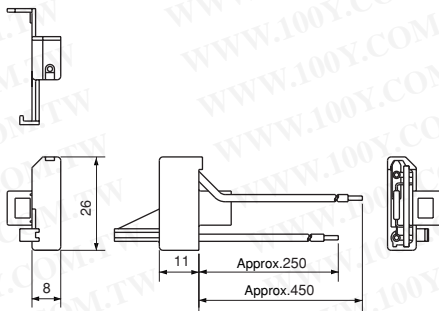

Reset release button

SZ-R1
SZ-R2
SZ-R3

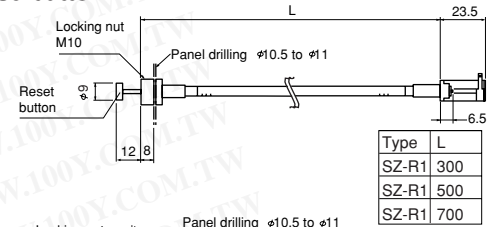

Type	L
SZ-R1	300
SZ-R1	500
SZ-R1	700

SZ-R4
SZ-R5
SZ-R6

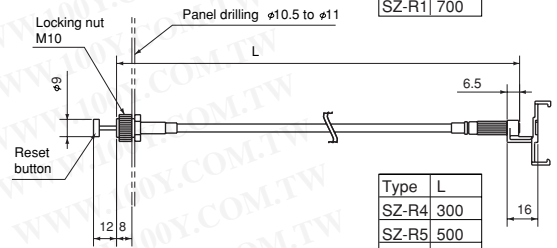

Type	L
SZ-R4	300
SZ-R5	500
SZ-R6	700

Dial cover
SZ-DA

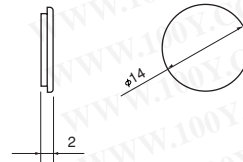

■ Characteristic curves These curves show cold starting characteristics.

● Standard type

TR-0N, 5-1N,
TR-0N/3, 5-1N/3,
TR-0NH, 5-1NH,
TR-0NH/3, 5-1NH/3

TR-N2 to N8
TR-N2/3 to N8/3
TR-N2H, N3H, N6H
TR-N2H/3, N3H/3, N6H/3

TR-N10 to N14,
TR-N10/3 to N14/3,
TR-N10H to N14H
TR-N10H/3 to N14H/3

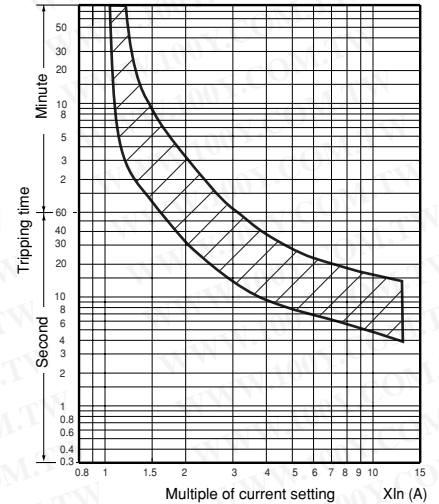
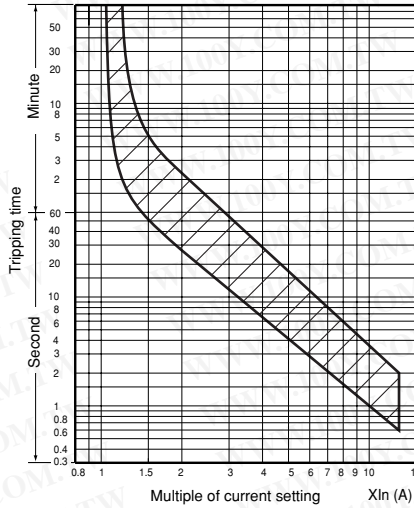
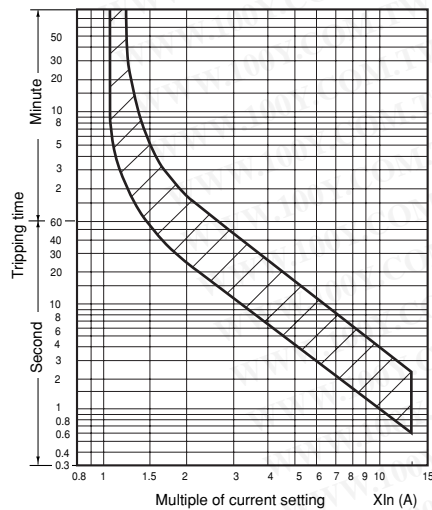

■ Wiring diagrams

● Standard type

TR-0N to N8
TR-0N/3 to N8/3
TR-0NH, 5-1NH, N2H, N3H, N6H
TR-0NH/3, 5-1NH/3, N2H/3, N3H/3, N6H/3

TR-N10 to N14
TR-N10/3 to N14/3
TR-N10H to N14H
TR-N10H/3 to N14H/3

2-element

3-element

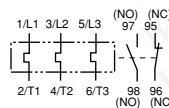
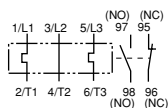

2-element (with CTs)

3-element (with CTs)

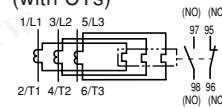
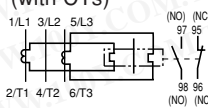

■ **Characteristic curves** These curves show cold starting characteristics
 ● **Long time operating type** (When setting at the center dial current)

TR-0NL, 5-1NL
 TR-0NL/3, 5-1NL/3
 TR-0NLH, 5-1NLH
 TR-0NLH/3, 5-1NLH/3

TR-N2L to N7L
 TR-N2L/3 to N7L/3
 TR-N2LH, N3LH, N6LH
 TR-N2LH/3, N3LH/3, N6LH/3

TR-N10L to N14L
 TR-N10L/3 to N14L/3
 TR-N10LH to N14LH
 TR-N10LH/3 to N14LH/3

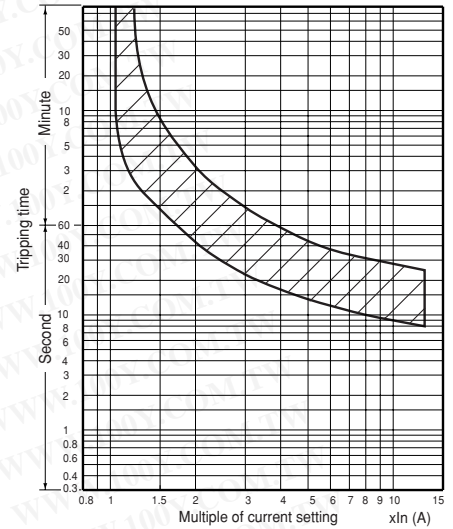
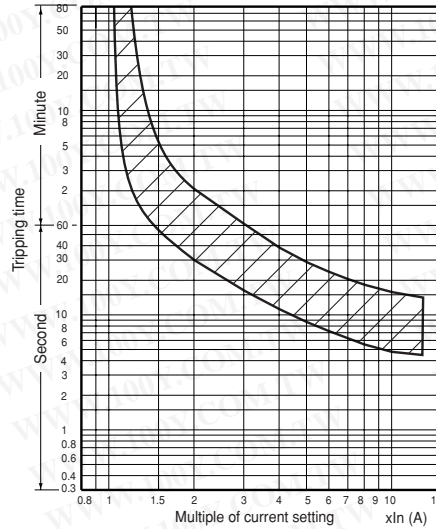
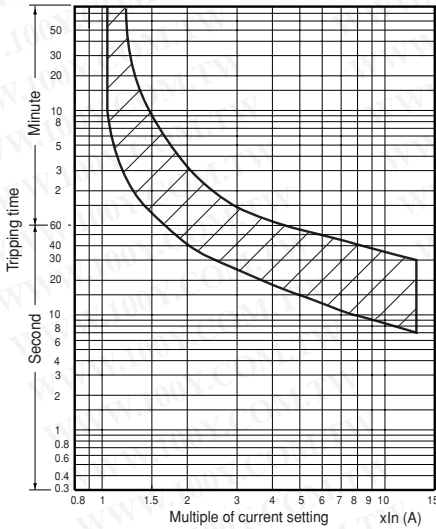

● **Quick operating type**
 TR-0NQ, 5-1NQ

TR-N2Q, N3Q, N5Q

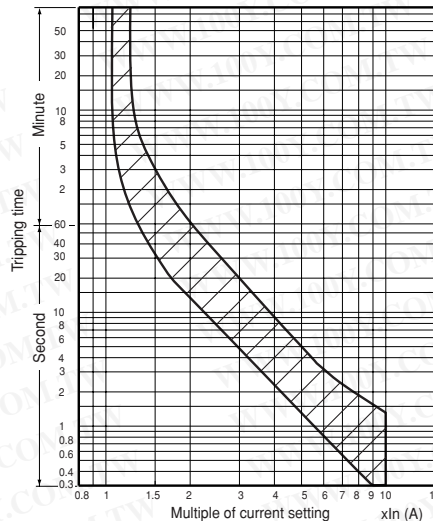
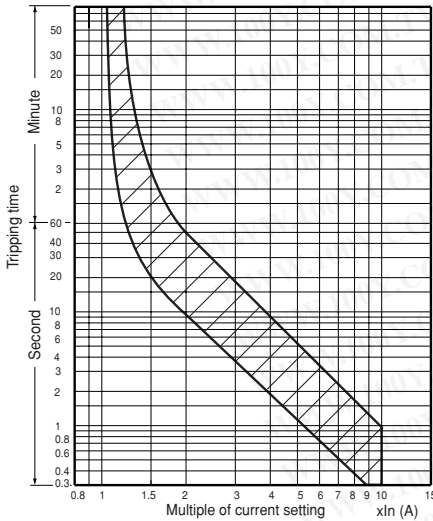

■ **Wiring diagrams**

● **Long time operating type**

TR-0NL to N7L
 TR-0NL/3 to N7L/3
 TR-0NLH, 5-1NLH, N2LH, N3LH, N6LH
 TR-0NLH/3, 5-1NLH/3, N2LH/3, N3LH/3, N6LH/3

2-element

3-element

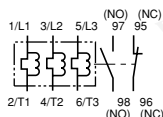
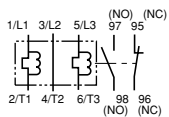

TR-N10L to N14L
 TR-N10L/3 to N14L/3
 TR-N10LH to N14LH
 TR-N10LH/3 to N14LH/3

2-element
 (with CTs)

3-element
 (with CTs)

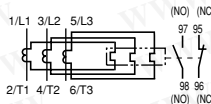
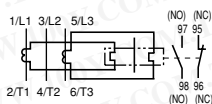

● **Quick operating type**
 TR-0NQ, 5-1NQ
 TR-N2Q, N3Q, N5Q

3-element

